

# Design and Implementation of Pick and Place Robotic Arm

Ravikumar Mourya<sup>1</sup>, Amit Shelke<sup>2</sup>, Sourabh Satpute<sup>3</sup>, Sushant Kakade<sup>4</sup>, Manoj Botre<sup>5</sup>

<sup>1, 2, 3, 4</sup> Student, <sup>5</sup> Assistant Professor, Department of Mechanical Engineering, JSPM Narhe Technical Campus Pune

---

**Abstract:** Robot manipulator is an essential motion subsystem component of robotic system for positioning, orientating object so that robot can perform useful task. The main objectives of this project are to design and implement a 4-DOF pick and place robotic arm. This project can be self-operational in controlling, stating with simple tasks such as gripping, lifting, placing and releasing. In this project, the focus is on 4-DOF articulated arm. Articulated arm consists of revolute joints that allowed angular movement between adjacent joint. Four servo motors were used in this project to perform four degree of freedom (4-DOF). There are numerous dimensions over which robotic arms can be evaluated, such as torque, payload, speed, range, repeatability and cost, to name a few. Robot manipulators are designed to execute required movements. Their controller design is equally important. The robot arm is controlled by a serial servo controller circuit board. The controller used for servo motor actuation is ATmega 16 Development board.

**Keywords:** picks and place, 4-DOF robotic arm, manipulator, gripper, Servo motor, AT mega 16.

---

## 1. INTRODUCTION

The field of robotics has its origins in science fictions. The word robot comes from the Czech word "robota" means forced labor in 1920. It took another 40 years before the modern technology of industrial robotics began. Today, robots are highly automated mechanical manipulators controlled by computers. A robot may appear like a human being or an animal or a simple electro-mechanical device. A robot may act under the direct control of a human (e.g. the robotic arm of the space shuttle) or autonomously under the control of a programmed computer. Robots may be used to perform tasks that are too dangerous or difficult for humans to implement directly (e.g. nuclear waste cleanup) or may be used to automate repetitive tasks that can be performed more cheaply by a robot than by the employment of a human (e.g. automobile production) or may be used to automate mindless repetitive tasks that should be performed with more precision by a robot than by a human (material handling, material transfer applications, machine loading and unloading, processing operations, assembly and inspection).[4]

The last two decades have witnessed a significant advance in the field of robots application. Many more applications are expected to appear in space exploration, battlefield and in various actives of daily life in the coming years. A robot is a mechanical device that performs automated tasks and movements, according to either pre-defined program or a set of general guidelines and direct human supervision. These tasks either replace or enhance human work, such as in manufacturing, contraction or manipulation of heavy or hazardous material. Robot is an integral part in automating the flexible manufacturing system that one greatly in demand these days. Robots are now more than a machine, as robots have become the solution of the future as cost labor wages and customers demand. Even though the cost of acquiring robotic system is quite expensive but as today's rapid development and a very high demand in quality with ISO standards, human are no longer capable of such demands. Research and development of future robots is moving at a very rapid pace due to the constantly improving and upgrading of the quality standards of products.[3]

### 1.1 PROBLEM STATEMENT:

To solve the problems of pick and place the cylindrical object having 6 cm diameter and 150 gram weight from one conveyor to another at room temperature in order to reduce human efforts and efficient material handling. The distance between two conveyers is 50 cm.

## 2. DESIGN OF ROBOTIC ARM

The mechanical construction in this project is to build and assemble the robotic arm body. After giving a thorough consideration of all the preceding works in this field, a four degree of freedom manipulator having variable programmed motions to carry out variety of tasks in diverse environments is chosen. This is a four axis articulate manipulator designed to move material like machine parts, tools, specialized devices, etc. It is driven by four servomotors and has a gripper as end-effectors. The gripper has fingers grasping and manipulation of objects as big as a 150 ml cylindrical bottle and having a weight of about 150 gm throughout the arm's workspace.

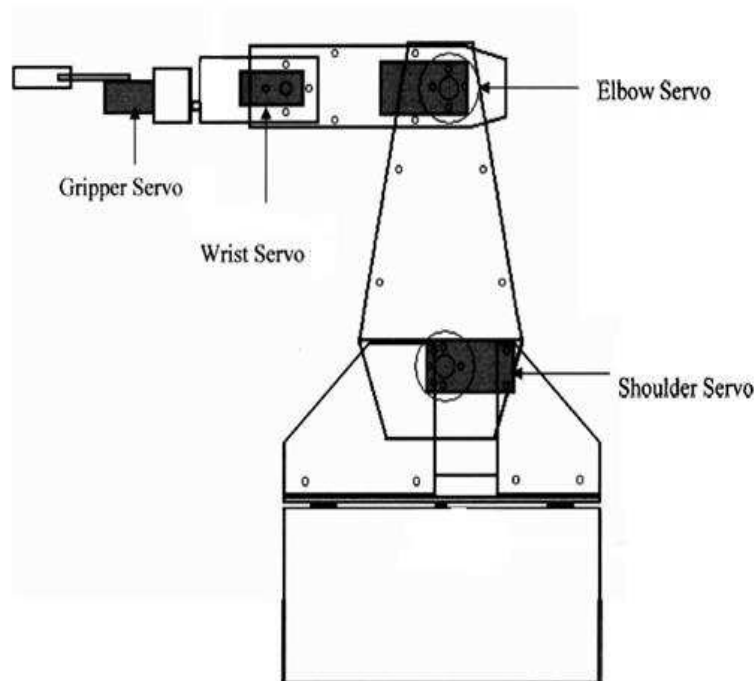

Figure 1: Design Overview of Robotic Arm.

### 2.1 DESIGN CONSIDERATION:

The following were put into consideration in the design process.

- i. Electrical actuators DC servo are chosen instead of hydraulic and pneumatic actuators because of the little power requirement and its light weight which is suitable for this design.
- ii. Materials used for the fabrication were locally sourced from available materials.
- iii. The materials which will be used for the design will be light in weight so as to reduce the weight concentration on the base and the shoulder.
- iv. Rectangular sheets instead of blocks are chosen for the links because of their light weight and stability and to reduce the weight of the arm.
- v. A continuous path controller was chosen (PIC microcontroller was used).
- vi. The torque is fully balanced by the inertia of the electric motors.

## 2.2 SELECTION OF DEGREE OF FREEDOM (DOF):

The number of independent movements that an object can perform in 3D space is termed as the number of degree of freedom (DOF). Thus, a rigid body free in space has six degree of freedom – three for positions and three for orientations. For our application 4 DOF are suitable.

## 2.3 MATERIAL SELECTION:

The most suitable material to fabricate the structure of the arm has to be light and strong. Otherwise, the servo motor will not be able to pull up the arm and to perform the desired turning degree. Among the materials that can be considered to fabricate the structure are aluminum, Perspex, plastic polymer and carbon fiber. In choosing the fabrication materials, the aspect of availability of the materials, the overall cost and the flexibility to be shaped, should also be taken into consideration. Thus among the four materials considered, the aluminum is the most ideal material to be chosen as fabrication material.

## 2.4 SPECIFICATIONS OF ROBOTIC ARM:

The robot arm for this project is the revolute type that closely resembles the human arm. Shoulder that mounted on base can move the arm through 180 degrees, from horizontal to vertical on each side. The shoulder uses large-scale servo, provide the torque needed to lift the rest of the arm, as well as any object that it may be grasping. Attached to the shoulder piece is an elbow that can move through 180 degrees, also powered by a large-scale servo. The wrist is made up of one standard servo and can move through 180 degrees, in vertical direction. Attached to the wrist is a two-fingered gripper that utilizes a unique design built around a single standard servo.

Table no. 4.6: Specification of robotic arm.

**Table No.1: Specification of robotic arm**

Specification	Value
Number of axes	4
Horizontal reach	230 mm
Vertical reach	130 mm
Drives	4 servo motors
Configuration	4 Axes plus gripper. All axes completely independent. All axes can be controlled simultaneously.
Work Envelope	(a) Shoulder Rotation -150 degrees (b) Elbow Rotation -180 degrees (c) Wrist Rotation -180 degrees (d) Gripper Rotation -90 degrees

## 3. CAD MODELLING OF ROBOTIC ARM

Considering the all points in designing, CAD model (Creo software) is used for robotic arm design. Various component of robotic arm is shoulder, elbow, wrist, grippers. The purpose of utilizing this Creo software is because Creo can provide a detail, real images and walk through overviews for demonstrating design. The 3D views of various parts of robotic arm are shown in fig. 2-8.

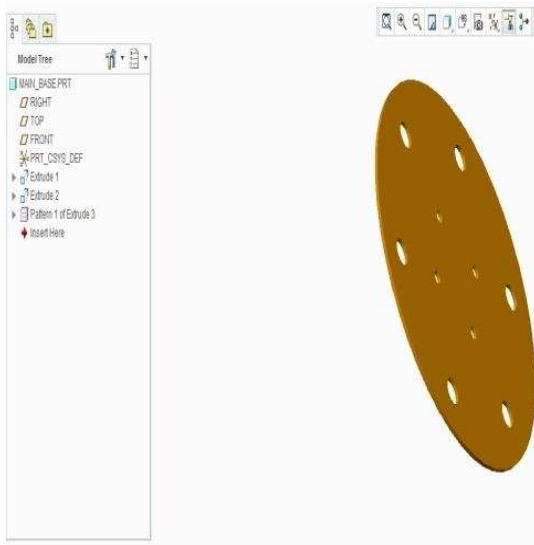

Figure 2: 3D view of Base Plate

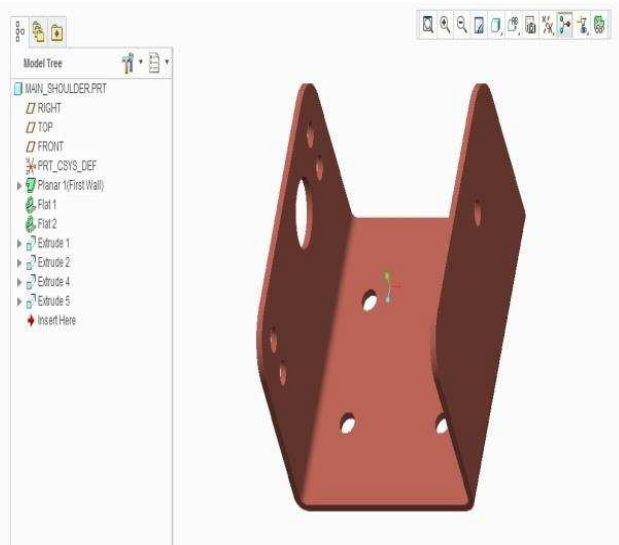

Figure 3: 3D view of Shoulder Base

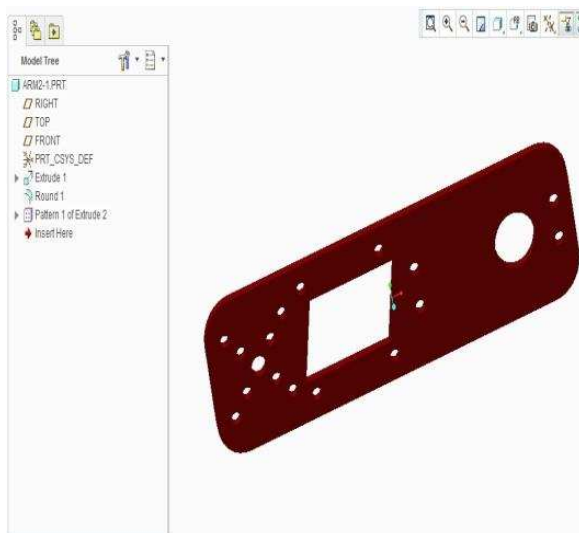

Figure 4: 3D view of Shoulder

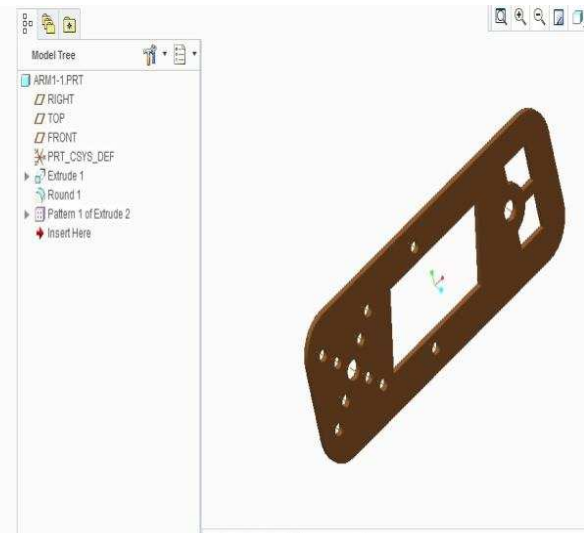

Figure 5: 3D view of Elbow

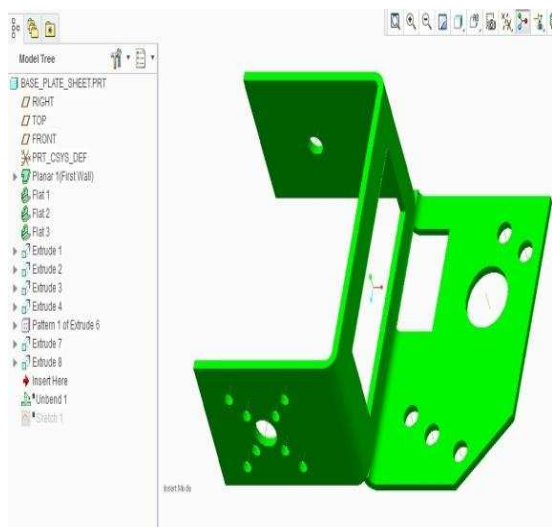

Figure 6: 3D view of Gripper Base

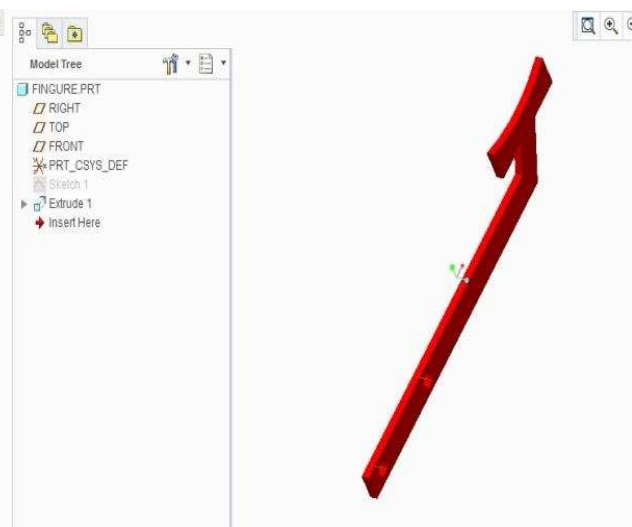

Figure 7: 3D view of Finger

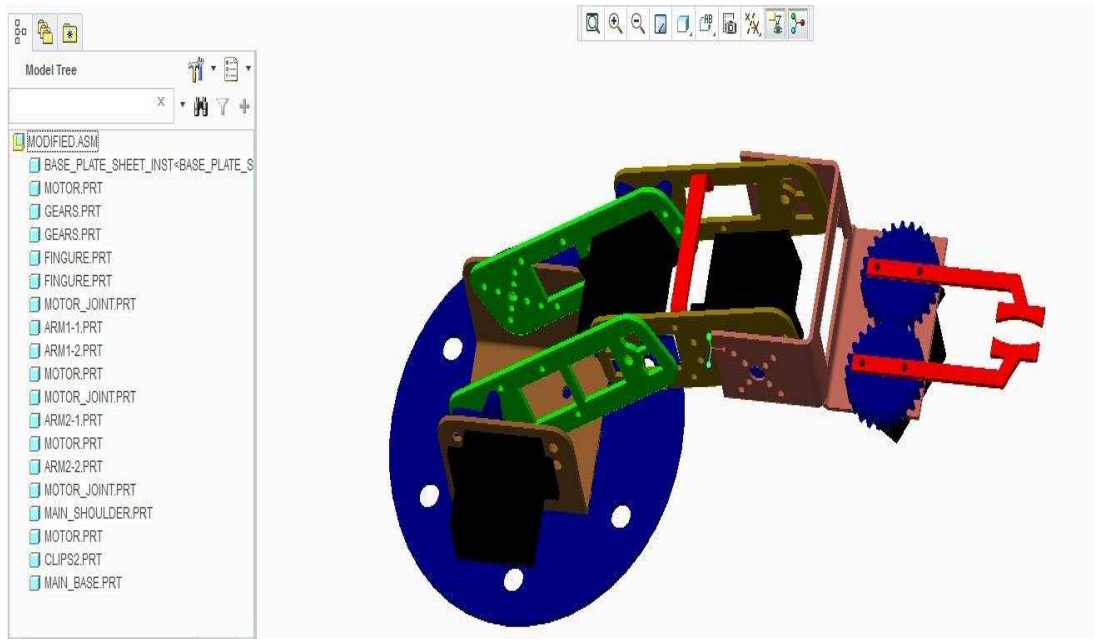

Figure 8: 3D view of full Assembly

#### 4. INVERSE KINEMATICS ANALYSIS

In order to control the position and orientation of end- effector of a robot arm to reach its object, the inverse kinematics solution is more important. In this project, inverse kinematics problem is solved by RoboAnalyzer 3D Model Based Robotics Learning Software. RoboAnalyzer is developed in the Mechatronics Lab, Department of Mechanical Engineering at IIT Delhi, India under the guidance of Prof. S. K. Saha.

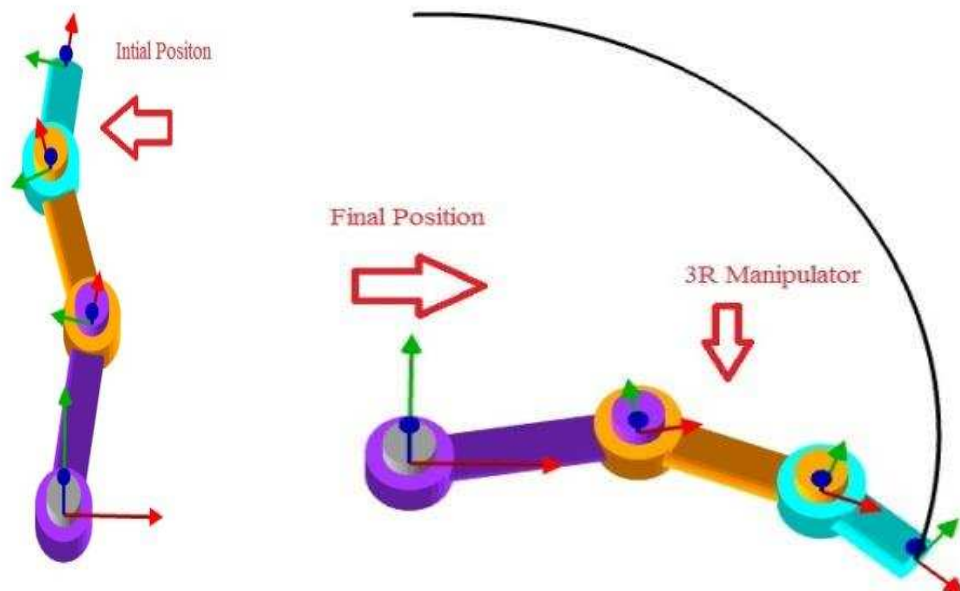

Figure 9: Initial and final position of Robotic arm.

The position and orientation of the end-effector in terms of given joint angles is calculated using a set of equations and this is forward kinematics. This set of equations is formed using DH parameters obtained from the link coordinate frame assignment. The parameters for the manipulator are listed in Table 4.5.1, where  $\theta$  is the rotation about the Z-axis,  $\alpha$  rotation about the X-axis, d transition along the Z-axis, and  $a$  transition along the X-axis.

Table 2: DH kinematic parameter table

Axis	Type	Joint angle $\theta$ in degree	Link length $d_i$ in m	Joint Offset $a_i$ in m	Twist angle $\alpha_i$ in radian
1	Shoulder	$\theta_1$	0.13	0	0
2	Elbow	$\theta_2$	0.11	0	0
3	Base	$\theta_3$	0.07	0	0

Giving these information to RoboAnalyze Software for finding the joint angle ( $\theta$ ) for different positions of robotic arm. Following results are obtained:

Table 3: Joint angles for different positions of end effector

Sr. No.	Positions	$\theta$ in case 1	$\theta$ in Case 2
1	X = 0.23 Y = 0.02	$\theta_1 = -35.59$ $\theta_2 = 96.02$ $\theta_3 = -60.42$	$\theta_1 = 49.84$ $\theta_2 = -96.02$ $\theta_3 = 46.17$
2	X = 0.08 Y = 0.08	$\theta_1 = 25.49$ $\theta_2 = 141.87$ $\theta_3 = -167.37$	$\theta_1 = 140.25$ $\theta_2 = -141.87$ $\theta_3 = 1.62$
3	X = 0.12 Y = 0.12	$\theta_1 = 17.32$ $\theta_2 = 115.0$ $\theta_3 = -132.35$	$\theta_1 = 117.43$ $\theta_2 = -115.0$ $\theta_3 = -2.40$
4	X = 0.17 Y = 0.19	$\theta_1 = 37.99$ $\theta_2 = 53.28$ $\theta_3 = -91.27$	$\theta_1 = 86.48$ $\theta_2 = -53.28$ $\theta_3 = -33.20$
5	X = 0.02 Y = 0.23	$\theta_1 = 91.90$ $\theta_2 = 22.61$ $\theta_3 = -114.52$	$\theta_1 = 112.61$ $\theta_2 = -22.61$ $\theta_3 = -90.00$

Where case 1 and case 2 are two different trajectory of robotic arm which is suitable for our project application. We can select any one of them. Some Graphs output come out from RoboAnalyzer Software by providing initial positions and final positions in term of joint angle as below:

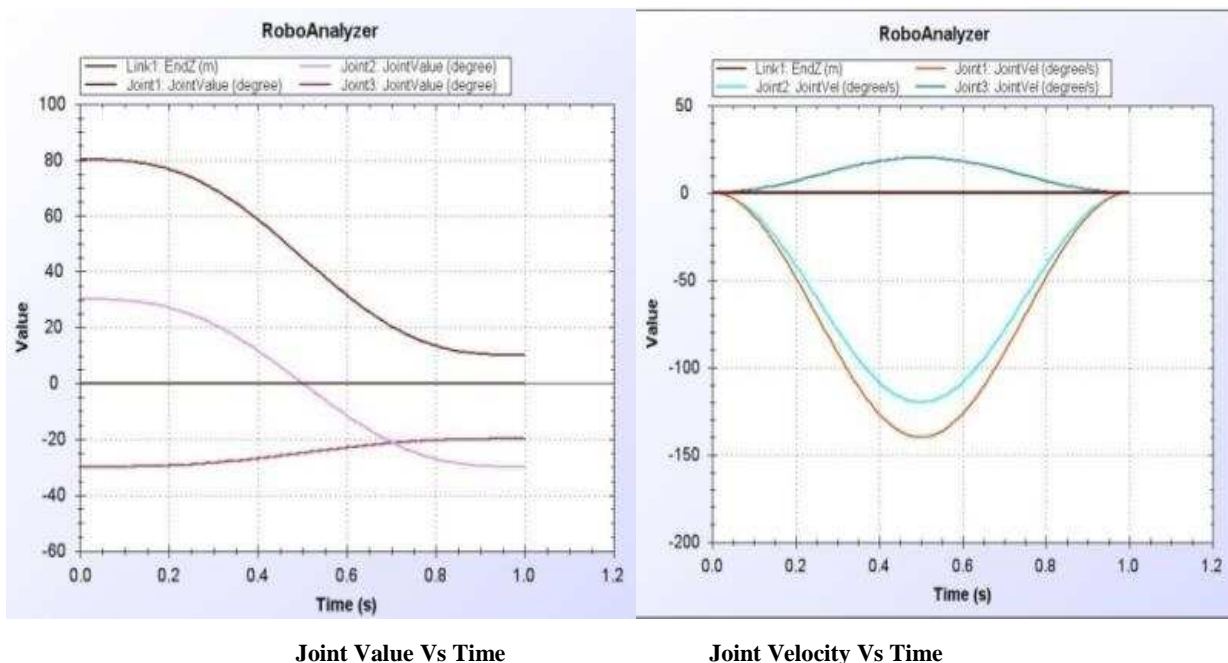



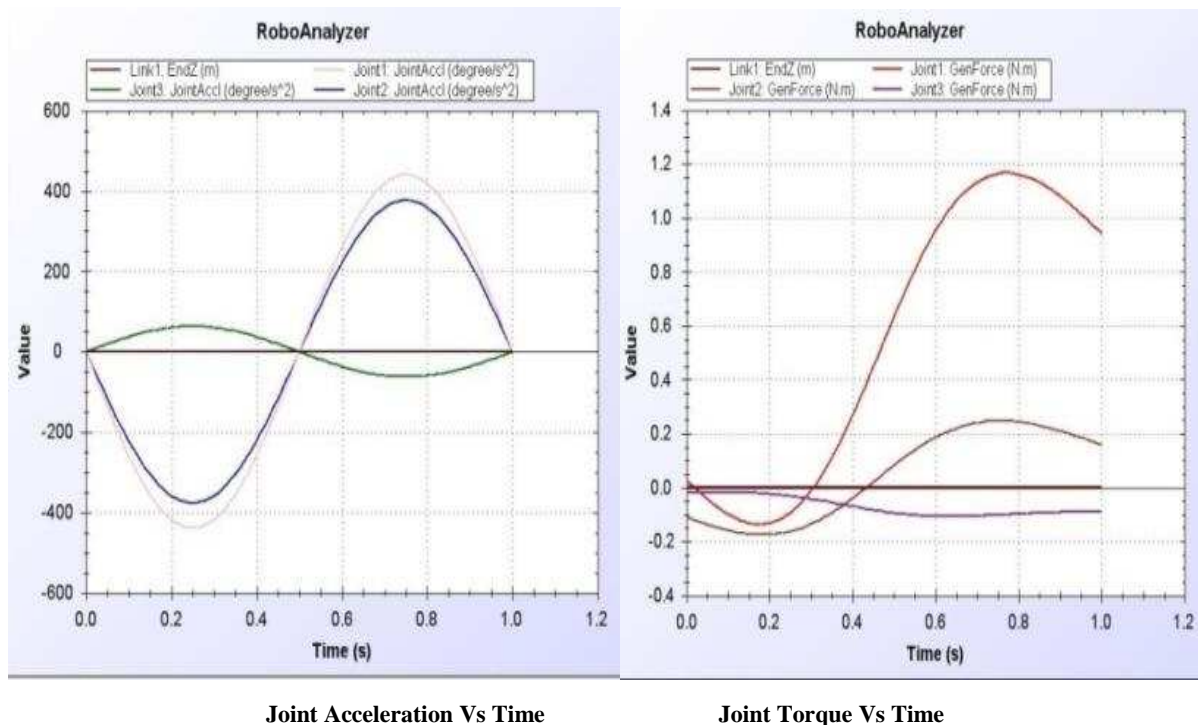

Figure 10: Graphs obtained by RoboAnalyzer Software.

### 5. FE ANALYSIS

Ansys software uses the displacement formulation of the finite element method to calculate component displacements, strains, and stresses under internal and external loads. The geometry under analysis is discretized using tetrahedral (3D), triangular (2D), and beam elements, and solved by either a direct sparse or iterative solver. SOLIDWORKS Simulation also offers the 2D simplification assumption for plane stress, plane strain, extruded, or axis symmetric options. Ansys Software can use either an h or p adaptive element type, providing a great advantage to designers and engineers as the adaptive method ensures that the solution has converged.

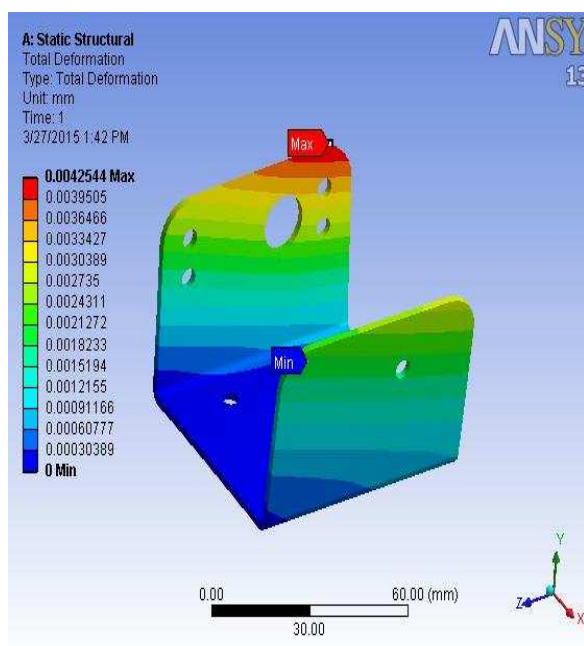

Figure 11: Total Deformation of Shoulder Base

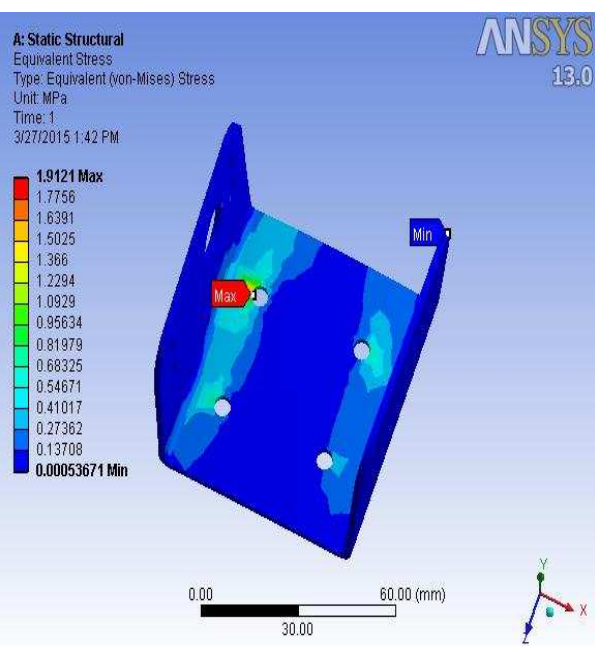

Figure 12: Stress on Shoulder Base

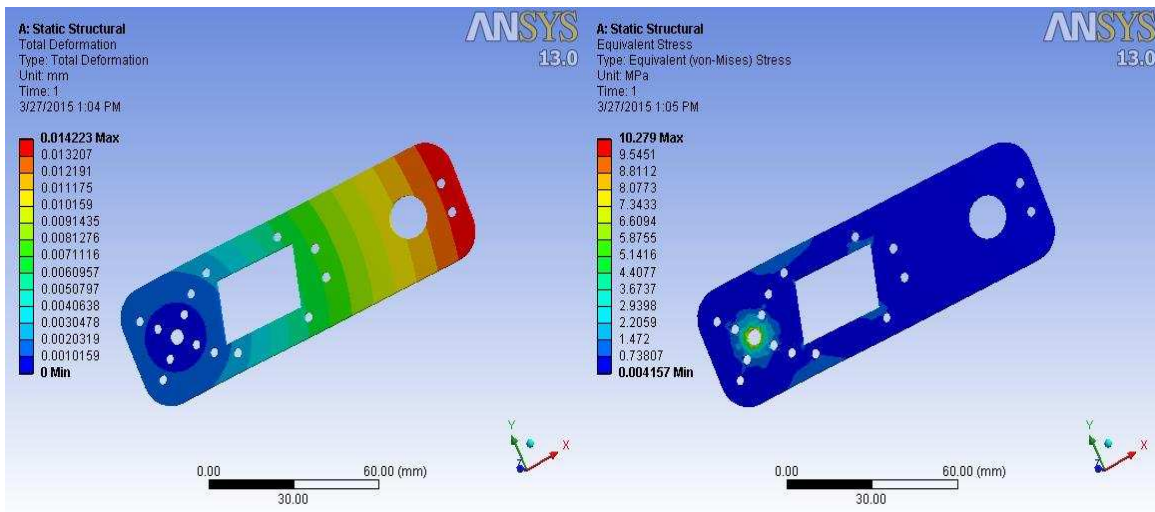

Figure 13: Total Deformation of Shoulder

Figure 14: Stress on Shoulder

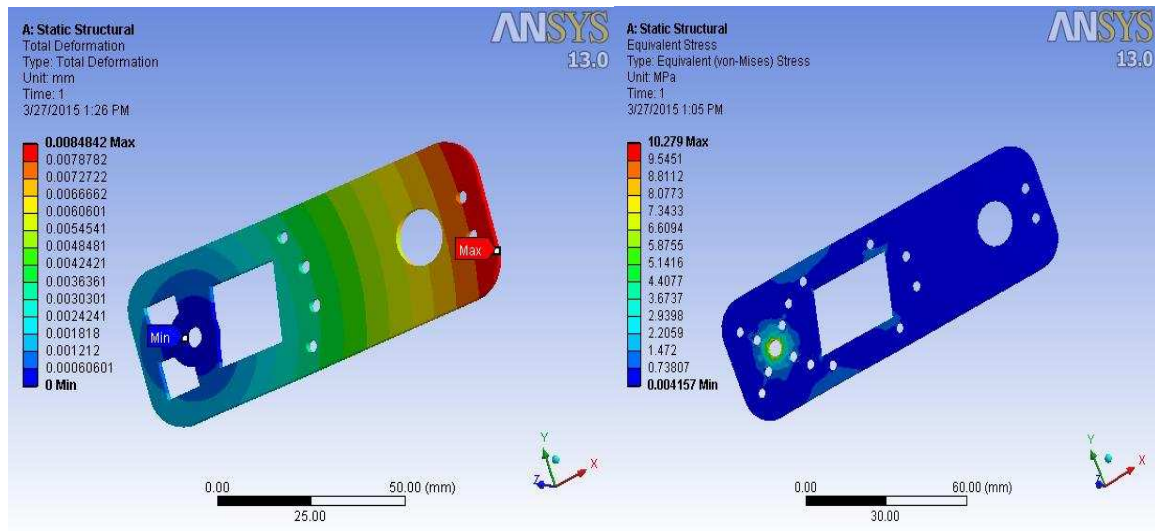

Figure 15: Total Deformation of Elbow

Figure 16: Stress on Elbow

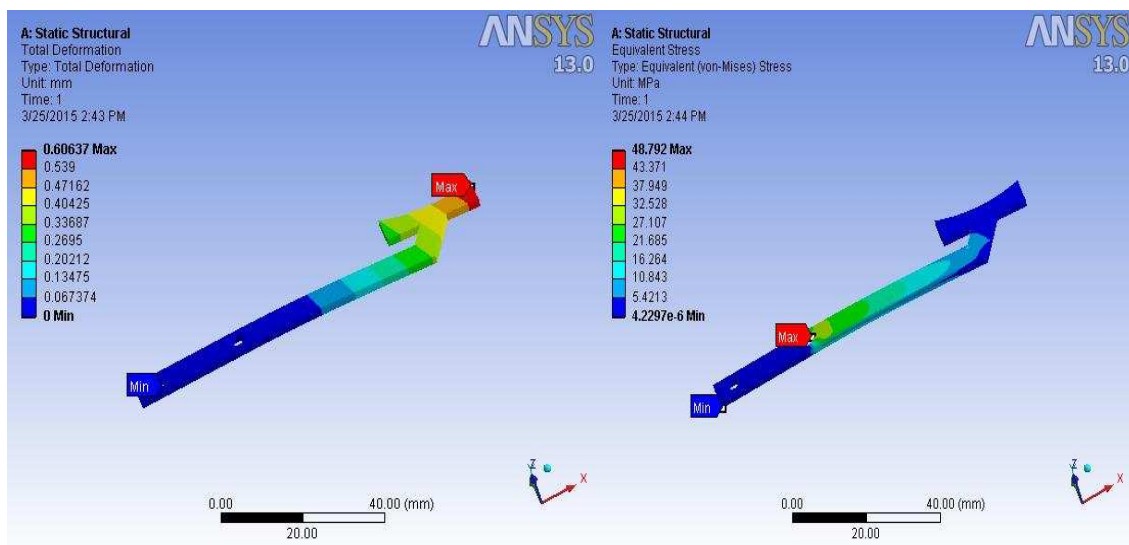

Figure 17: Total Deformation of Finger

Figure 18: Stress on Finger



## 6. CONCLUSION

In this project we are designing and fabricating of a 4-DOF manipulator has been successfully completed. With reference to many available manipulators and mobile platforms in market, a practical design for the manipulator has been perceived and computer aided designing tools like Creo 1.0 and AutoCAD are used to model the desired manipulator. Theoretical analysis of the inverse kinematics was carried out to determine the end effectors position and orientation. FE Analysis is done by using ansys software.

## REFERENCES

- [1] B.O. Omijeh, R. Uhumwangho, M. Ehikhamenle, “Design Analysis of a Remote Controlled Pick and Place Robotic Vehicle”, International Journal of Engineering Research and Development, Volume 10, PP.57-68, May 2014.
- [2] Elias Eliot, B.B.V.L. Deepak, D.R. Parhi, and J. Srinivas, “Design & Kinematic Analysis of an Articulated Robotic Manipulator”, Department of Industrial Design, National Institute of Technology-Rourkela.
- [3] Sanjay Lakshminarayan, Shweta Patil, “Position Control of Pick and Place Robotic Arm”, Department of Electrical Engineering MS Ramaiah Technology, Bangalore, India.
- [4] Mohamed Naufal Bin Omar, “Pick and Place Robotic Arm Controlled By Computer”, Faculty of Manufacturing Engineering, April 2007.
- [5] Ankit Gupta, Mridul Gupta, Neelakshi Bajpai, Pooja Gupta, Prashant Singh, “Efficient Design and Implementation of 4-Degree of Freedom Robotic Arm”, International Journal of Engineering and Advanced Technology (IJEAT) ISSN: 2249 – 8958, Volume-2, June 2013.